

INSTALLATION INSTRUCTIONS

Before you begin, disconnect the pump from its electrical source and plug the pool skimmer and return ports.

Do not be alarmed if the timer display is not active when the timer is unpacked. The internal battery will be charged when power is connected to the pump after installation. Let the internal battery charge for five minutes before programming or operating the timer.

CAUTION: You must use the Cord Assembly and Jumper Wires furnished with your timer kit. Failure to do so will void your warranty and could result in a short circuit causing damage to your timer.

PP I & PP II

1. Remove the 6 screws that secure the top housing to the pump assembly.
2. Remove motor cover plate is so equipped.
3. Disconnect wiring from the timer and motor.
4. Remove strain relief bushing and cord from bottom housing and discard.
5. From inside of housing, remove the 4 screws securing the timer. Remove timer and set aside.
6. Install the new Timer/Bracket Assembly inside top housing using 4 screws previously removed.
7. Install new cord and strain relief bushing into bottom housing. Be sure there is adequate cord length to make wiring connections.

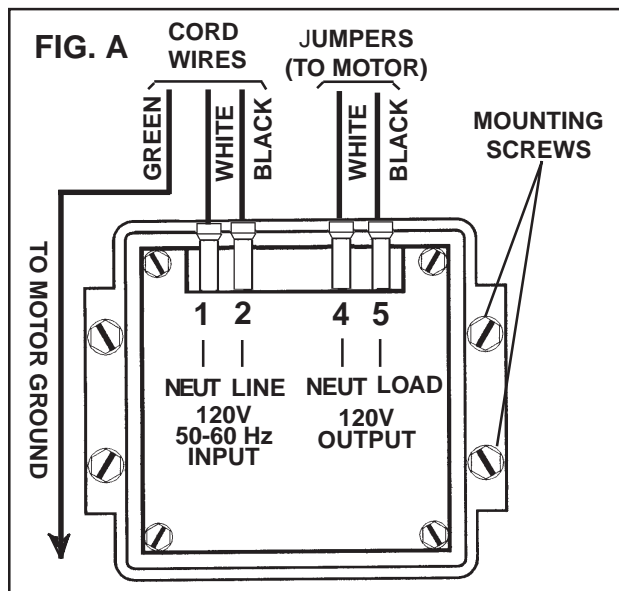

CAUTION: To prevent a short circuit, use only the supplied cord and jumper wires with insulated terminals for timer electrical connections.

8. Connect the cords black and white wires to the timer as shown in Fig. A. Connect the green wire to the motor ground.
9. Connect the insulated end of black and white jumper wires to the timer as shown. Connect opposite ends of jumper wires with straight connectors to the motor terminals. Replace motor cover.
10. Reinstall top housing using 6 screws.
11. Plug cord into receptacle and check that the display is on. It will take several minutes to energize the timer battery.

CAUTION: Do not operate pump dry. Damage to the shaft seal could occur.

IMPORTANT: The timer cover should remain closed whenever possible to protect the display from water or sunlight damage.

PP III

1. Remove 4 plastic wingnuts and 4 screws holding the motor housing to the back plate.
2. Remove motor cover plate.
3. Disconnect wiring from the timer and motor.
1-1/2 HP Only: Disconnect all wiring from the relay. It will not be used with this timer kit.
4. Remove strain relief bushing and cord from motor housing and discard.
5. From outside motor housing, remove 4 screws holding the timer. Remove timer.

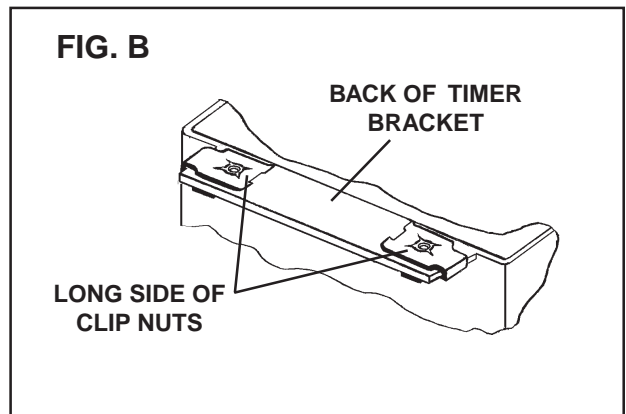

- Remove clip nuts from old timer and install onto flanges of new timer bracket. The longer side of clip must be on the back side of timer bracket flange (see Fig. B). Install the new Timer Bracket Assembly inside motor housing using 4 screws previously removed.
- Install new power cord and strain relief bushing into motor housing. Be sure there is adequate cord length to make wiring connections.

CAUTION: To prevent a shorted circuit, use only the supplied cord and jumper wires with insulated terminals for timer connections.

- Connect the cords black and white wires to the timer as shown in Fig. A. Connect the green wire to the motor ground.

- Connect the insulated end of the black and white jumper wires to the timer as shown. Connect opposite ends of jumper wires with straight connectors to the motor terminals. Replace motor cover.
- Reinstall motor housing using 4 screws and four wing nuts.
- Plug cord into receptacle and check that the display is on. It will take several minutes to energize the timer battery.

CAUTION: Do not operate pump dry. Damage to the shaft seal could occur.

IMPORTANT: The timer cover should remain closed whenever possible to protect the display from water or sunlight damage.

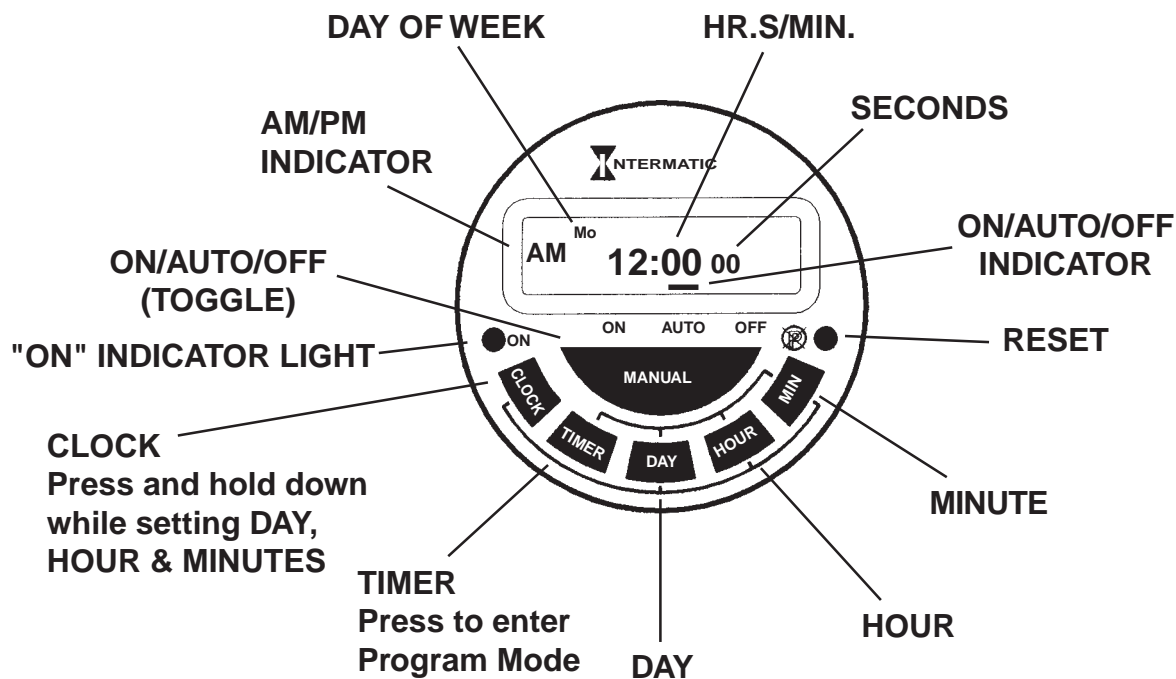

PUMP TIMER PROGRAMMING INSTRUCTIONS

Reset

Press the  key to reset the timer (use a ballpoint pen). Day, time and programs will be cleared from the timer.

To Set Day and Time

- Press and hold down **Clock** button..
- Press **Day** button repeatedly until the current day of the week is displayed.
- Continue to hold down clock button and press **Hour** button until the correct hour is displayed.
- Continue to hold down clock button and press the **Minute** button until the correct minute is displayed.
- Release the **Clock** button. The day and time are now set.

For most pool owners, a 7 day a week filtering schedule will satisfy their water quality requirements. Programming instructions for a 7 Day schedule are provided below for those pool owners.

Quick Program (Pump On and Off at the same time each day, Monday through Sunday)

After Day and Time are set, proceed to the steps below.

- Press **Timer** Button to enter Program mode.
- Press **Day** button repeatedly until Monday through Sunday appears across top of display window.
- Press **Hour** Repeatedly until desired ON Time Hour is displayed.
- Press **Minute** button repeatedly until desired ON Time Minute is displayed.
- Press **Timer** button again to toggle to OFF time mode.
- Press **Hour** button repeatedly until desired Off Time Hour is displayed.
- Press **Minute** button repeatedly until desired OFF Time Minute is displayed.
- Press **Clock** button to exit programming mode.

Your Pump Timer is now programmed to start and stop Monday through Sunday at the same time each day.

Additional Programs

Although the above program will meet most pool owners filtering needs, your Pump Timer is designed so that any of fifteen (15) separate programs may be used. They are as follows:

1. Monday, Tuesday, Wednesday, Thursday, Friday, Saturday and Sunday (7 Days-**Quick Program**)
- 2-8. Monday only, Tuesday only, Wednesday only, etc. (1 day)
9. Monday through Friday (5 weekdays)
10. Saturday and Sunday (Weekend)
11. Monday through Saturday (6 days)
12. Monday, Wednesday and Friday (3 days)
13. Tuesday, Thursday and Saturday (3 days)
14. Monday, Tuesday and Wednesday (3 Days)
15. Thursday, Friday and Saturday (3 days)

To select one of the above programs, simply set Day and Time and proceed as follows:

- Press **Timer** button to enter Program Mode.
- Press **Day** button repeatedly until the desired program (1 through 9 above) is displayed.
- Follow the steps above for Quick Program to set Hour and Minute ON and OFF Times.

Note: When setting **OFF** times for programs 2 through 15, you must first press **DAY** to select the day(s) that corresponds to the day(s) selected for ON times.

Manual ON and OFF

Press **Manual** button to toggle pump to **Manual ON**, **Manual OFF** or **Auto Mode**.

- To Operate pump in **Auto Program** mode, Toggle the Manual button until black line at bottom of display window is over Auto.
- To manually turn pump on or off, press **Manual** button until black line at the bottom of display window is over the desired setting (**ON** or **OFF**).

SERVICE

In the event service is required, contact your local **Authorized Doughboy Pool Dealer**.

SERVICING SAFETY TIPS

A. ALWAYS TURN "OFF" the main power switch and the ground fault interrupter (GFCI) breaker switch so power is completely off before servicing your unit.

B. ALWAYS BE SURE THE GROUND UNDER YOUR FEET AND YOUR BODY IS DRY before you touch electrical equipment. Failure to heed this warning may cause personal injury due to severe electrical shock.

CAUTION: To reduce the risk of electric shock, connect only to grounding type receptacles. A Ground Fault Interrupter (GFCI) must be provided in accordance with local codes and ordinances.

CAUTION: To reduce the risk of electric shock, use only Original Equipment Manufactured (OEM) replacement parts when servicing.

PARTS LIST - POWER PAK TIMER KITS

POWER PAK TIMER KIT MODEL NO.					
PPI & II (U.L.) PPI & II (NEC) PPIII - (U.L.)					
1121-1566 1121-1567 1121-1568					
ITEM	PART NO.	PART NO.	PART NO.	QTY.	DESCRIPTION
*1	1121-1564	1121-1564	1121-1564	1	Timer/Bracket Assembly
2	340-2211	340-2211	340-2211	1	Timer Bracket
3	1100-1669	1100-1669	1100-1672	1	White Jumper Wire
4	1100-1668	1100-1668	1100-1671	1	Black Jumper Wire
5	1100-1667	1100-1666	1100-1670	1	Power Cord - U.L.
6	303-1104	303-1120	303-1715	1	Strain Relief Bushing
7	330-1276	330-1276	330-1276	4	4-20 X 5/16" Mach.Screw
8	369-1237	369-1237	369-1237	1	Installation Instructions

* ONLY SOLD AS REPLACEMENT FOR KITS 1121-1566, 1121-1567, AND 1121-1568

"the original portable pool"



TWO YEAR LIMITED WARRANTY

Power Pak Timer Unit

Retain this warranty along with your sales receipt and/or proof of purchase.

1. Doughboy is the sole warrantor of this product.
2. This warranty is extended to the original purchaser (consumer) only.
3. Doughboy Recreational warrants the Timer Unit to be free from defects in material and workmanship, provided it is installed and operated according to the factory instructions.
4. Should and Timer Unit prove to be factory defective within ninety days of purchase date, it will be replaced at your Doughboy Dealer/Authorized Service Center without charge to the original purchaser (consumer).
5. Should any Timer Unit prove to be factory defective after ninety days but prior to two years from date of purchase, it will be replaced at your Doughboy Dealer/Authorized Service Center at no charge to the original purchaser (consumer) Labor charges are not covered.
6. This warranty is null and void if the design of this product is altered in any way. Thus, the product must be assembled according to the factory directions and no changes or modifications may be made to any of the parts.
7. This warranty gives specific legal rights; the purchaser also has implied warranty rights which may vary from state to state.

Terms of sale of our warranty exclude liability for willful carelessness.

Change of Design: Doughboy Recreational expressly reserves the right to change or modify the design and construction of any product in due course of our manufacturing procedures, without incurring any obligation or liability to furnish or install such changes or modifications on products previously or subsequently sold.



DOUGHBOY RECREATIONAL • 10959 Jersey Blvd., • Rancho Cucamonga, CA 91730
 Visit our website at: www.doughboy-pools.com