



10" Anti-Vortex Maindrain

(For Vinyl Liner Pools)
Model 0-2020-000

Owner's Guide

WARNING

A risk exists with any maindrain suction outlet as it relates to the possibility of a swimmer becoming entrapped on the maindrain due to high velocity suction. This can occur if the swimmer's body completely covers the flow openings at a time when there is no suction flow from a skimmer or other sources.

Never allow swimmers to enter the pool when all of the water is being drawn to the filter through the maindrain only (all other suction valves are closed).

For maintenance, particularly sweeping of the pool floor, it is desirable to have all of the suction at the maindrain during that process. However, when maintenance is completed, suction should be controlled so as to draw water from both the maindrain and a skimmer or other source (explained later).

There is a potential LOSS OF LIFE SITUATION. If a swimmer in the pool were to sit under water and completely cover the maindrain outlet or were to swim down and place his or her stomach over the top of the maindrain, that swimmer could be held in that position without being able to free himself or herself from the maindrain until the pump is completely shut off. The result could be a PREVENTABLE, TRAGIC DROWNING. REMEMBER, DO NOT ALLOW SWIMMERS TO USE THE POOL IF WATER IS BEING DRAWN FROM THE MAINDRAIN ONLY.

INSTALLATION

Locate the maindrain at the deepest point in the pool floor. For flat bottom pools, it is good practice to provide at least a 4" gentle slope on the floor from the pool wall down to the maindrain. This will allow good drainage and aid in winterizing (explained later).

DIG SUMP AND TRENCH

Carefully dig out the location for the maindrain sump body to the dimensions shown. Dig the pipe trench 12" beyond the pool wall location near the proposed pump location. (Refer to "suction piping diagram," Fig. 13)

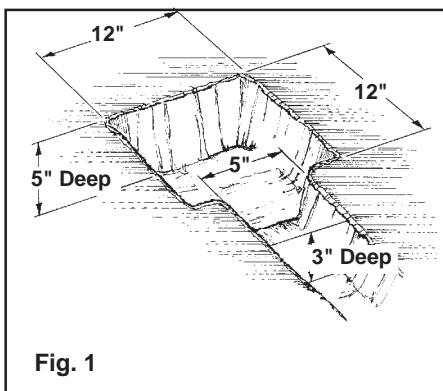

Deep Excavated Pools

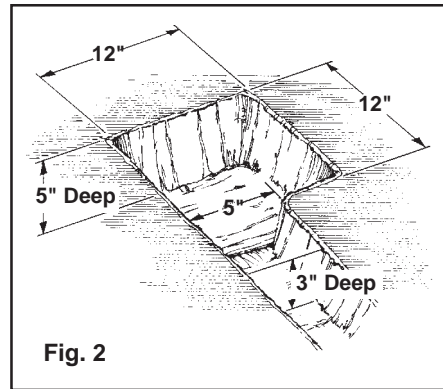

Flat Bottom Pools

MASK SCREW HOLES

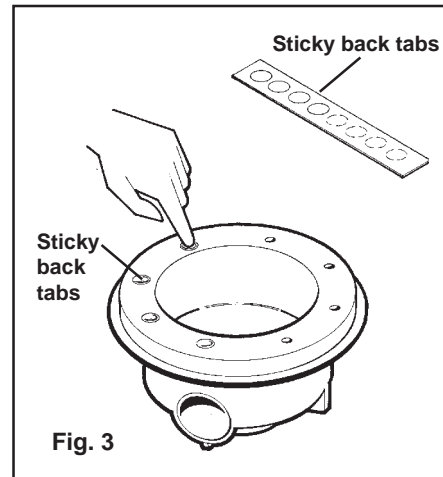

Peel off round, sticky back tabs and cover the 8 screw holes on the sump body flange. Press these tabs firmly so that the screw hole indentation shows but is still covered. This will prevent dirt from accidentally filling holes. Dirt could prevent screws from securing properly. Do not drill out holes as eventual leakage will occur.

POSITION SUMP BODY

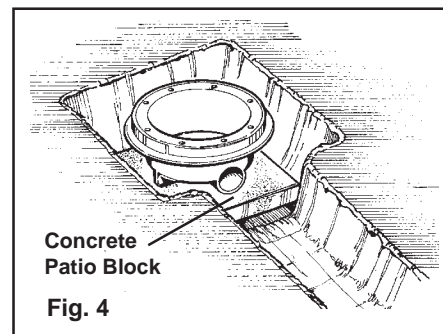

You may elect to place a concrete patio block under the sump body, leveling the top surface with the ground. Or, encase the body in concrete after piping is installed. NOTE: Do not back fill under patio block as the body will settle down to firm soil. Scrape soil away under the patio block, repeating the process until level.

INSTALL PIPING

For Flat Bottom Pools

Use 1 1/2" schedule 40 PVC pipe and fittings. It is important for a flat bottom pool that the pipe runs from the maindrain to the outside of the pool wall and slopes upwards towards the wall, a rise of between 2" to 4" (for details, see Figure 5). Install an elbow in the maindrain sump body to accomplish sloping pipe to wall and maintain the levelness of the sump. Install a riser pipe, with a valve below the threaded end of same (see Figures 5 & 6). NOTE: The valve shown is for illustration purposes only. The valve used must be capable of being air tight at all locations and most specifically around the control handle. The threaded end of the riser pipe is most important in freezing climates for winterizing purposes.

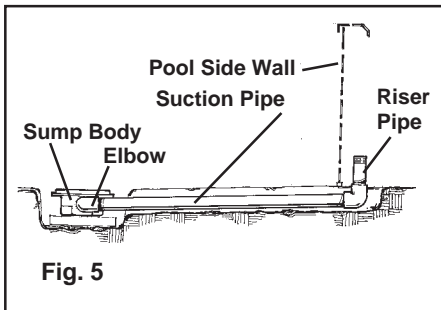

Flat Bottom Pools

For Excavated Pools

Install piping directly into sump body and route to upper ground surface using 45° elbows as shown in Figure 6.

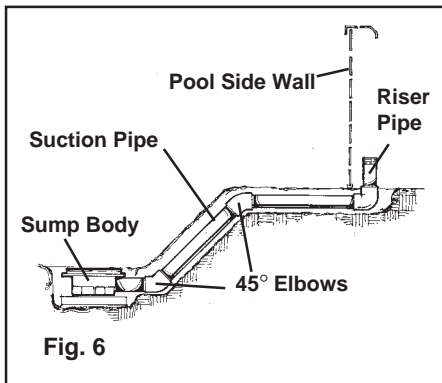

Excavated Pools

CEMENTING JOINTS

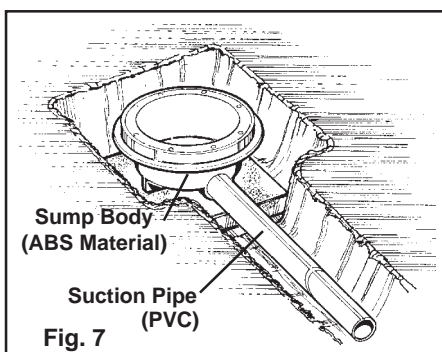

The sump body is made of ABS material and the suction pipe is made of PVC, thus: **one must use a special ABS to PVC cement for this connection. All other joints use PVC cement only.** Follow cement manufacturer's instructions for preparing and cementing joints.

BACK FILL

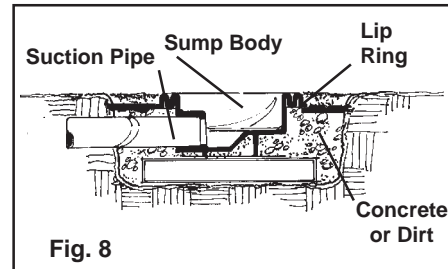

Do not back fill until all piping joints have completely cured per manufacturer's recommendations. Failure to do so may result in leakage. If concrete is used to encase the sump body, pour to the level of the lip ring only (3/4" below the top of the sump body).

Back fill using damp earth and firmly pack around piping and maindrain to prevent settling. Level top of body to ground surface. Remove any dirt particles on body surface. NOTE: Avoid getting dirt in maindrain during pool installation.

INSTALL LINER

NOTE: Liner installation techniques vary, and, it will be necessary to enter and exit the pool while installing the main drain. To enter or exit the pool, release tension on the liner at one section only. Before continuing the work, re-establish the tension of the liner according to instructions.

It is very important that once the liner makes contact with top of sump body, the liner should not be allowed to shift in any direction. This will prevent dirt particles from being swept onto the sealing surface.

Do not place the gasket on sump body prior to installing the liner. Only one gasket is used on top of the liner and beneath the mounting ring after the liner is positioned. This sump body incorporates a sealing bead on the flange to effect a seal with the liner. Install the liner per manufacturer's instructions until such time that it is in direct contact with and covering the sump body.

Continue to fill the pool with water until the water is approximately 4" deep at the area of the sump body. This will allow water pressure to hold the liner in place for the next step which will be the placement of the gasket and the mounting ring provided.

PLACE GASKET AND MOUNTING RING

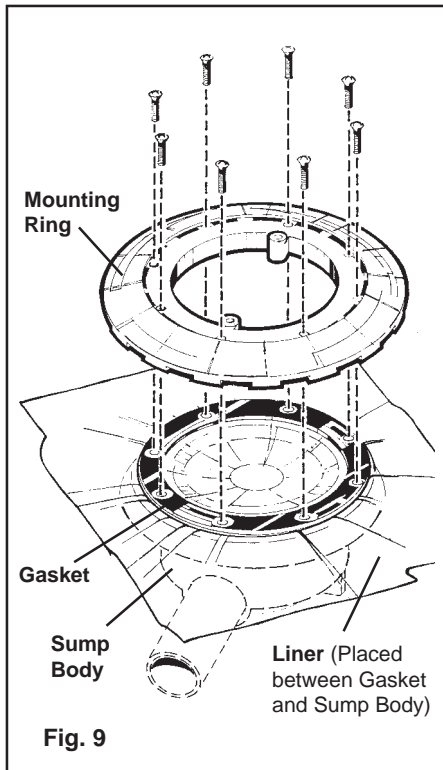

The weight of the water will dish the liner in the center of the sump body and highlight the sealing bead on the sump body flange. The 8 screw holes are between the dished area and the sealing bead. Locate one of these holes (soft spot) using your fingernail. When one is located, push a pencil or carpenter's nail through the liner into the screw hole.

Insert one screw through the mounting ring and gasket and align over the hole you pierced. Turn screw one or two turns to insure engagement while allowing mounting ring and gasket to pivot freely. Place a second screw through mounting ring and gasket on opposite side of mounting ring. Center them around dished area of the liner. Insure gasket and mounting ring move together. Apply downward force on screw to locate hole in sump body flange; turn screw one or two turns to insure engagement.

With these two screws in place, install remaining 6 screws. In each case, after tightening one screw securely, go across to the other side of the sump body and tighten down the opposing screw. Repeat this process (similar to tightening a wheel on a car). See Figure 10 - it does not matter where the actual location of the first tightened screw is located.

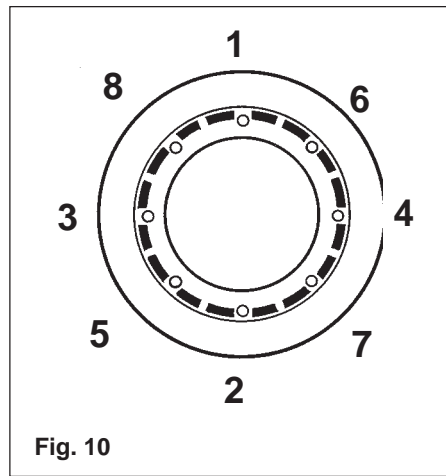

TRIM LINER

Using a razor knife, trim out and remove liner piece in sump body as shown. Take care not to drop the razor knife or accidentally puncture the liner outside the ring area.

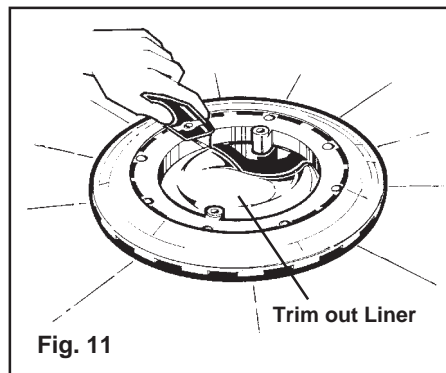

INSTALL COVER

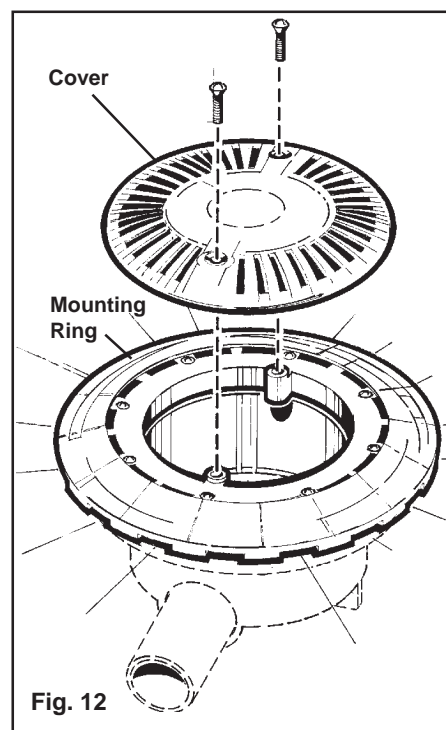

Position cover inside mounting ring, aligning the two holes thru the cover and the mounting ring holes. Evenly tighten screws; there is no need to over tighten.

Before continuing to fill the pool, close the maindrain valve on the riser pipe.

Finish the pool assembly and filling with water per manufacturer's recommendations.

SUCTION PIPING DIAGRAM

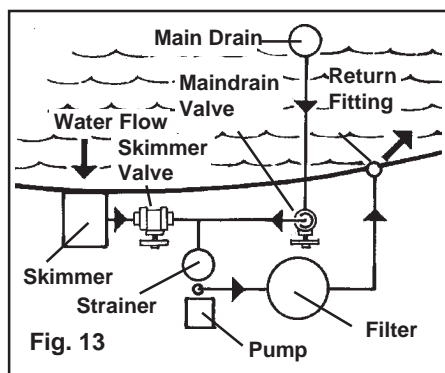

This diagram illustrates the general piping arrangement for locating the skimmer, pump and filter and may vary with positioning depending on product types and manufacturer's requirements. This arrangement allows for the control of water suction flow (shown by use of directional arrows in figure 13) as required for most pool operations.

OPERATIONS

NOTE: The maindrain's maximum continuous operating flow is 40 G.P.M.

Normal Filtering

The maindrain valve should be opened 10-15% and the skimmer valve opened 85-90%. These positions provide good circulation for chemical distribution and allows the skimmer to remove larger quantities of floating debris.

To Sweep Pool Floor

This operation requires full flow thru the maindrain valve and all other valves closed. (See Warnings).

Vacuum Thru Skimmer

This operation requires the maindrain suction valve to be closed and the skimmer valve full open. Follow skimmer manufacturer's instructions for vacuuming.

LOWERING POOL WATER LEVEL

For the purposes of servicing skimmer and/or winterizing, as explained next, it may be desirable to lower the water level in the pool. To do so, open the maindrain valve to full open and close other suction valves. If your filter system is equipped with a pump to waste feature, you may use the pump to lower the water level per local regulations. If your filter does not have the pump to waste

feature, you may have to detach the plumbing between the pump and the filter and attach an appropriate drain hose to the pump discharge. Reduce the water level so that it is just under the bottom skimmer opening and the eyeball return fitting. NOTE: Do not allow swimmers in the pool during this operation. Refer to WARNINGS prior to "Installation".

WINTERIZING

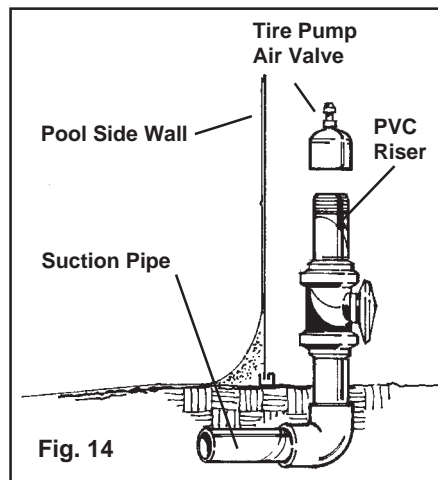

In freezing climates, prepare your pool to prevent freezing damage following manufacturer's instructions. After lowering pool water level (see previous section), the exposed maindrain piping must also be protected against freezing the water trapped inside the pipe.

This is accomplished by closing the maindrain valve and all other suction valves. Then detach existing plumbing from the maindrain riser pipe to the filter system.

Wrap the riser pipe threads with teflon plumber's tape (approximately 3 wraps).

Your pool dealer may have 1-1/2" threaded PVC caps in which he has drilled a hole in the center dome and installed a tire pump air valve. If not, you may be required to purchase such a cap from your local hardware store and drill a hole in the dome and insert your own tire pump air valve, making sure that it is securely sealed in the cap.

Install the threaded cap by screwing down tightly to make an air-tight seal. Now open the maindrain valve making sure there are no leaks. Connect tire pump to air valve on cap and pump air into line until significant air bubbles appear coming from the maindrain. Remove tire pump and check for any air leaks from the air valve, cap threads, or the maindrain valve body and control handle. NOTE: A little soapy water placed on these areas will assist in seeing air leaks.

If leaks are present, tighten cap and air valve and repeat the process. If the maindrain riser pipe has leakage at the maindrain valve, the air valve or the cap, contact your pool dealer. **The line must be air tight.**

Exploded Parts - Model 0-2020-000

Maindrain - Model 0-2020-000			
ITEM	P/N	QTY	DESCRIPTION
1	340-1768	1	Cover
2	330-1004	10	Screws
3	340-1769	1	Ring
4	308-1172	1	Gasket
5	340-1770	1	Sump Body
6	360-1587	1	Tabs
7	365-1668	1	Owner's Guide

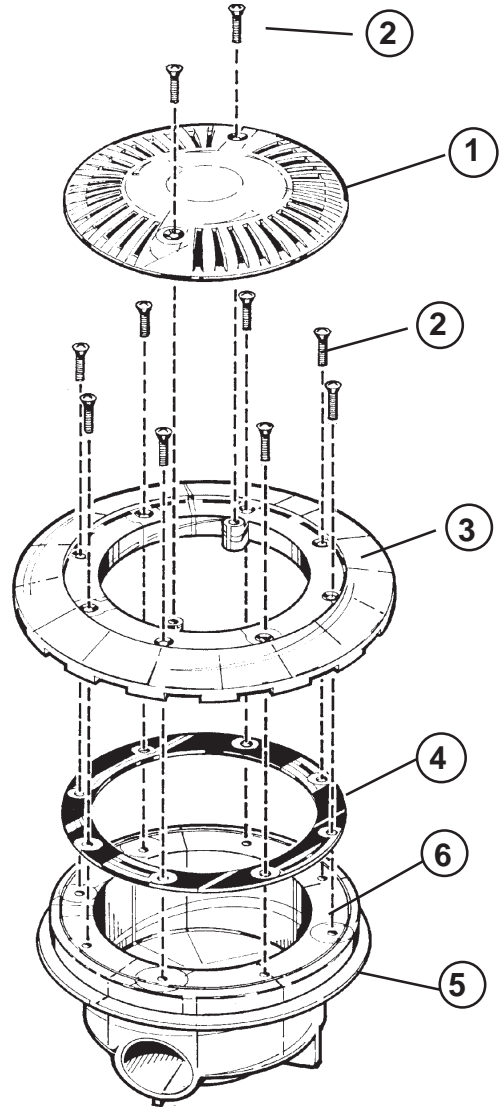

Change of Design: Doughboy Recreational expressly reserves the right to change or modify the design and construction of any product in due course of their manufacturing procedures, without incurring any obligation to furnish or install such changes or modifications on products previously or subsequently sold.

"the original portable pool"

doughboy®

DOUGHBOY RECREATIONAL • 10959 Jersey Blvd. • Rancho Cucamonga, CA 91730

DB794-041

Made in the United States of America

Copyright © 1994